

# SCUBAPRO

## Repair Guide

### MK 2 Plus











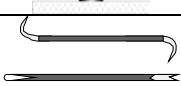

### First Stage





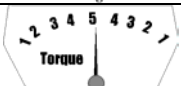

**USE THIS GUIDE AS A REFERENCE WHEN SERVICING  
THE MK 2 Plus FIRST STAGE**

***TOOLS NEEDED FOR REPAIR OF MK 2 PLUS FIRST STAGE***











Quantity	Part Number	Description	
1		Ratchet	
1	20-155-500	1" Yoke Nut Socket (Peter Built)	
1	43.300.210 (Scubapro)	Standard piston first stage seat removal tool.	
1 set	10.102.100 (Peter Built)	Brass o'ring picks	
1 tube	41.047.000	Christo-Lube	
1	47.010.000	Counter Mat	
1	41.496.101	Lubricant syringe	
1	43.040.000 (Scubapro)	Universal Tool	
1	20-115-100 (Peter Built)	First Stage Handle	
1		Torque Wrench	
1		Hex Key Set	
1		Crescent wrench	
1	20.500.200 (Peter Built)	Pneumatic Adjusting tool	
1	18.300.500	Blow Gun/Air Nozzle	



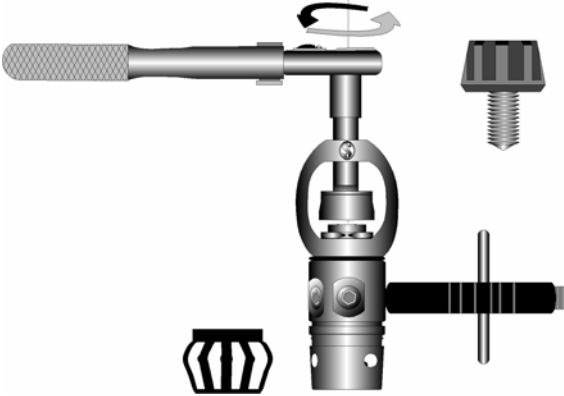
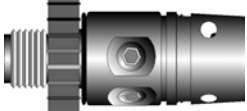

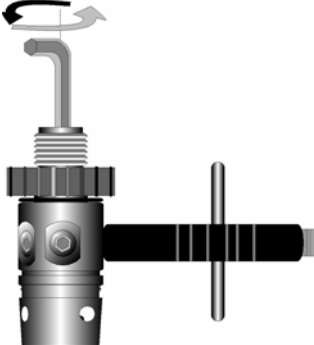
**ICON LEGEND**

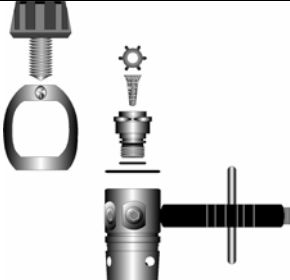
	Inspect carefully, replace if needed
	Lubricate properly
	Replace annually
	Dynamic o'ring, lubricate properly
	No tools needed for this step

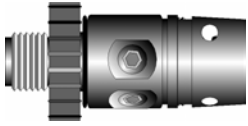
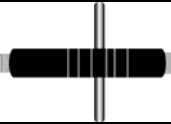
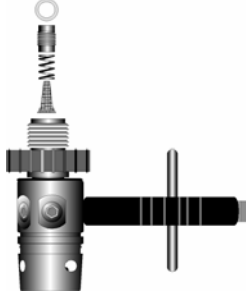
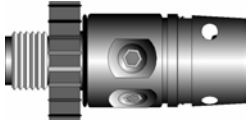

## SCUBAPRO MK 2 Plus First Stage

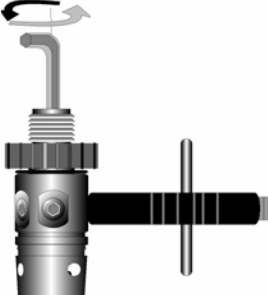
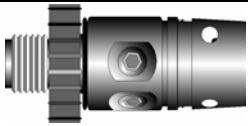

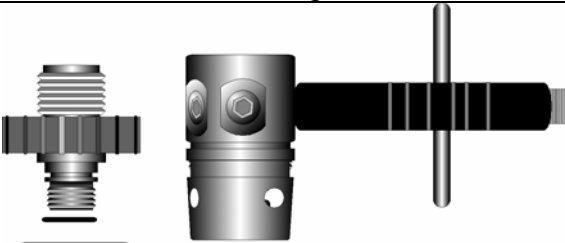
			
<p>Remove all hoses.</p> <p>Thread the first stage handle into the high-pressure port as shown.</p> <p>Use the ratchet and yoke nut socket to remove the yoke nut from the first stage.</p> <p>Remove the cap cover.</p>			
		 <p>5/32"</p>	
<p>Remove all hoses.</p> <p>Thread the first stage handle into the high-pressure port as shown.</p> <p>Loosen the filter retainer using a 5/32" hex wrench.</p>	<p>For DIN Regulators</p> 		
			
<p>Remove the yoke nut and yoke from the first stage body.</p> <p>Loosen the star clip and remove the filter.</p> <p>Remove the yoke nut o'ring.</p>			

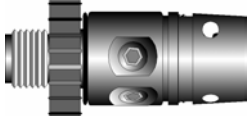
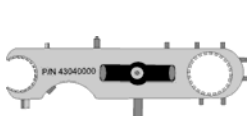

**SCUBAPRO MK 2 Plus First Stage**

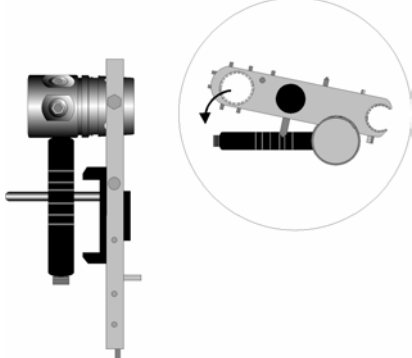
		
<p>Remove the filter retainer, spring, filter, DIN adapter and o'ring.</p>	<p>For DIN Regulators</p> 	
		 6mm
<p>Loosen the DIN fitting using a 6mm hex wrench.</p>	<p>For DIN Regulators</p> 	
		 6mm
<p>Remove the DIN fitting from the regulator body.</p> <p>Remove the DIN fitting o'ring.</p>	<p>For DIN Regulators</p> 	

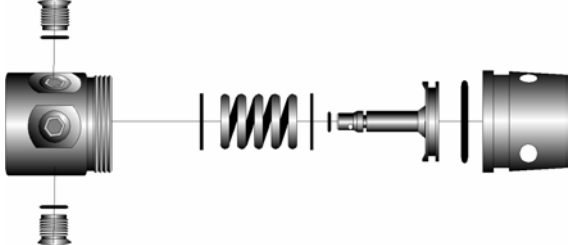

## SCUBAPRO MK 2 Plus First Stage

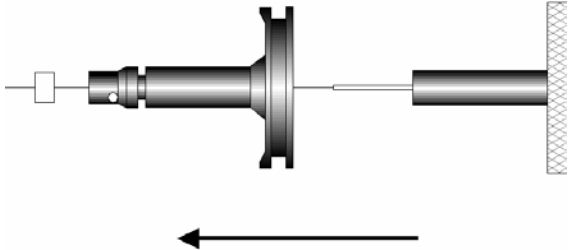

			
<p>Loosen the regulator cap from the regulator body using the universal tool and first stage handle.</p>			

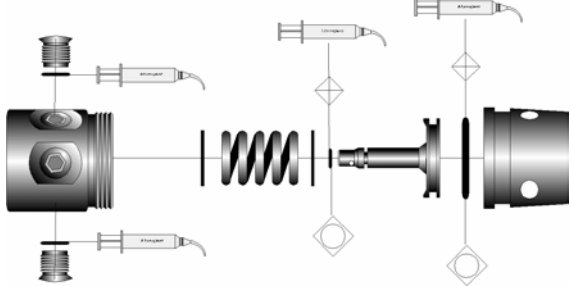

			<p>No tools needed this step</p>
<p>Separate the regulator body and cap. Carefully remove the piston assembly, spring and shims.</p>			

			
<p>Remove the high-pressure seat from the piston using the seat removal tool.</p>			



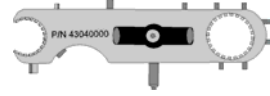
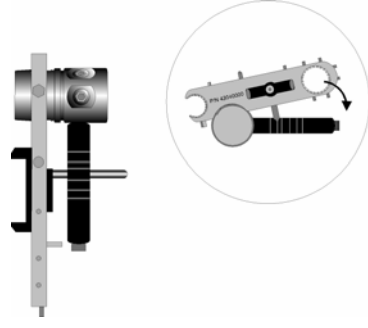

## SCUBAPRO MK 2 Plus First Stage

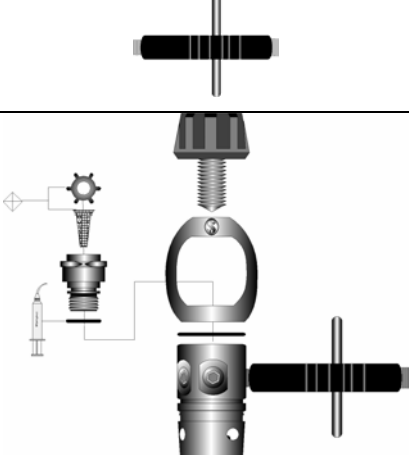
		
<p>Replace the piston head and piston stem o’rings. Lubricate these o’rings to dynamic specification.</p> <p>Insert the spring, seat assembly and shims into the regulator cap.</p>		

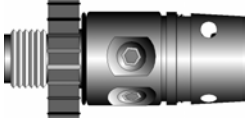

			
<p>Use the universal tool and first stage handle to tighten the regulator cap to the regulator body.</p>			

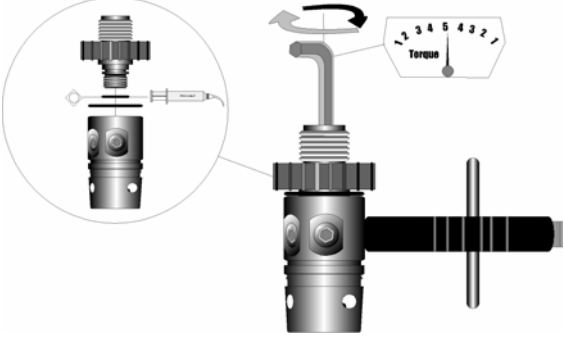
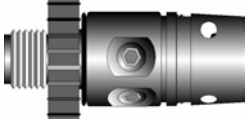

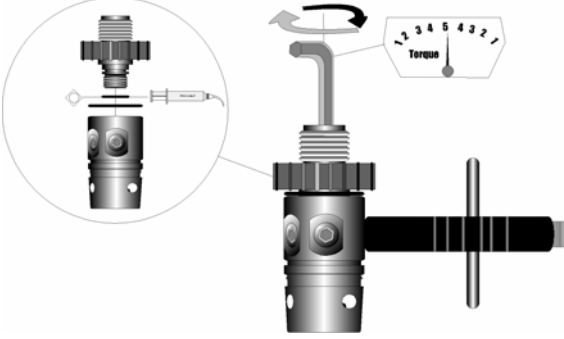

			
<p>Replace the filter and star retainer. Lubricate the yoke nut o’ring.</p> <p>Reassemble the yoke to the regulator body.</p>			

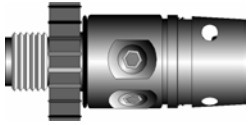

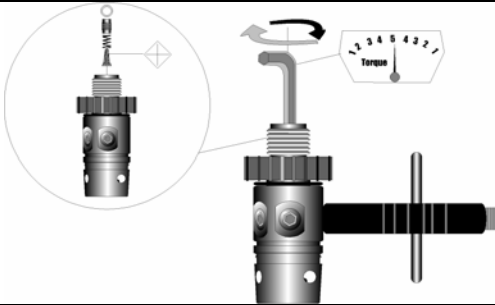
## SCUBAPRO MK 2 Plus First Stage

		 6mm
<p>Inspect and lubricate the DIN fitting-to-body o'ring.</p> <p>Attach the DIN fitting to the regulator body.</p> <p>Torque the DIN fitting to 266 in-lbs/30 N-m.</p>	<p>For DIN Regulators</p> 	
		 6mm
<p>Inspect and lubricate the DIN fitting-to-body o'ring.</p> <p>Attach the DIN fitting to the regulator body.</p> <p>Torque the DIN fitting to 266 in-lbs/30 N-m.</p>	<p>For DIN Regulators</p> 	

## SCUBAPRO MK 2 Plus First Stage

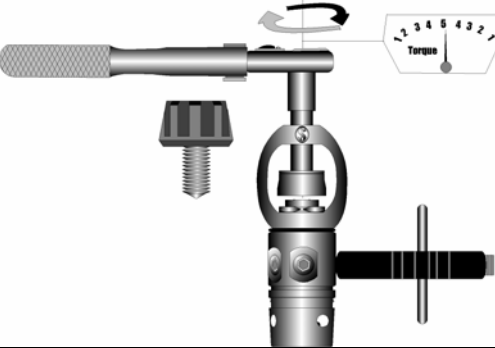
		 5/32"
For DIN Regulators		
<p>Insert a new filter, the spring, the filter retainer, and o'ring.</p> <p>Use a 5/32" hex wrench to tighten. Torque to 35 in-lbs/4 N-m.</p>		

				
<p>Tighten the yoke nut using the ratchet wrench and yoke nut socket.</p> <p>Torque the yoke nut to 266 in-lbs/30 N-m.</p>				

		
<p>Check the intermediate pressure using the pneumatic adjusting tool.</p> <p>Intermediate pressure should be 125psi – 145psi at 3000psi and 300psi supply pressure.</p>		